

# MEGP 25E/25LS ELECTRIC PARALLEL GRIPPERS

## USER MANUAL

For Firmware Version 9.3.x

Document Revision: A

May 29, 2023

The information contained herein is the property of Mecademic and shall not be reproduced in whole or in part without prior written approval of Mecademic. The information herein is subject to change without notice and should not be construed as a commitment by Mecademic. This manual will be periodically reviewed and revised.

While every effort has been made to ensure accuracy in this publication, no responsibility can be accepted for errors or omissions. Data may change, as well as legislation, and you are strongly advised to obtain copies of the most recently issued regulations, standards, and guidelines.

This document is not intended to form the basis of a contract.

*Original instructions*

© Copyright 2015–2023 Mecademic

# CONTENTS

- 1. INTRODUCTION ..... 1**
  - 1.1. Inside the box ..... 1
- 2. TECHNICAL SPECIFICATIONS ..... 2**
- 3. DESIGNING AND MOUNTING THE FINGERS ..... 3**
  - 3.1. MEGP 25E mounting diagrams ..... 3
  - 3.2. MEGP 25LS mounting diagrams ..... 4
- 4. INSTALLING THE GRIPPER ..... 6**
  - 4.1. Installation steps ..... 6
  - 4.2. Gripper LEDs ..... 8
- 5. OPERATING THE GRIPPERS ..... 9**
  - 5.1. Firmware update ..... 9
  - 5.2. Safety ..... 9
  - 5.3. Activation, homing and E-Stop ..... 9
  - 5.4. Maintenance ..... 10





## ABOUT THIS MANUAL

This user manual describes how to install and operate the MEGP 25E and MEGP 25LS (MEGP 25\*) electric grippers onto the Meca500 (R3 & R4) industrial robot arm. You must read this manual thoroughly before installing or operating the MEGP 25\* grippers.

### Symbol definitions

The following table lists the symbols that may be used in Mecademic documents to denote certain conditions. Particular attention must be paid to the warning messages in this manual.

SYMBOL	DEFINITION
	NOTICE. Identifies information that requires special consideration.
	CAUTION. Provides indications that must be respected in order to avoid equipment or work (data) on the system being damaged or lost.
	WARNING. Provides indications that must be respected in order to avoid a potentially hazardous situation, which could result in injury.



## 1. INTRODUCTION

The MEGP 25E and MEGP 25LS grippers (MEGP 25\* grippers) are electric parallel grippers developed by Mecademic and Schunk specifically for the Meca500 (R3 & R4) robot arm. The MEGP 25\* grippers use a removable connector cable.



Familiarity with the Meca500 robot and its user manual is required prior to installing and using the grippers.



Improper installation of the grippers could seriously damage the Meca500 and the grippers themselves. These grippers should therefore be used only by technical personnel who are familiar with the Meca500.

### 1.1. Inside the box

Each of the two gripper models is supplied either individually or with the Meca500. In both cases, the gripper is delivered in an anti-static bag containing the standard kit:

- 1 MEGP 25E or 1 MEGP 25LS gripper;
- 1 MGC-SS35 35-mm communication cable with straight connectors or  
1 MGC-AA25 25-mm communication cable with 90° connectors;
- 1 MEGP25-TAP adapter plate (made of non-anodized aluminum) for attaching the gripper to the Meca500's mechanical interface (flange);
- 4 M3X0.5 Torx flat head screws of length 8 mm;
- 2 M2.5X0.45 socket head screws of length 20 mm.



Note that we also offer an optional 90° adapter plate for each of the two grippers: M500-ATAP01 (for the MEGP 25E) and M500-ATAP02 (for the MEGP 25LS).



We do not supply gripper fingers. These must be designed and machined based on the workpiece that needs to be handled.

---

## 2. TECHNICAL SPECIFICATIONS

Table 1 lists the main technical specifications for both electric grippers. Further specifications are provided in the next section.

TECHNICAL SPECIFICATIONS		
Characteristic	Value for MEGP 25E	Value for MEGP 25LS
Maximum weight per finger	0.02 kg	0.02 kg
Maximum gripping force	40 N	40 N
Recommended maximum workpiece weight	0.2 kg	0.2 kg
Stroke per jaw	3 mm	24 mm
Repeatability	0.03 mm	0.03 mm
IP protection class	30	30
Power supply (nominal)	24 V, 0.14 A	24 V, 0.14 A
Noise emission	< 70 dB	< 70 dB
Housing	Coated aluminum alloy, steel	Coated aluminum alloy, steel
Total weight	0.106 kg	0.136 kg
Operating temperature	5° to 55°C	5° to 55°C
Operating humidity	10% to 95% RH (non-condensing)	10% to 95% RH (non-condensing)

Table 1: Technical specifications for the MEGP 25\* grippers

### 3. DESIGNING AND MOUNTING THE FINGERS

Fingers must be designed and installed before mounting the MEGP 25\* gripper on the Meca500. Designs must respect the measurements and maximum finger dimensions and loads provided in the following.

#### 3.1. MEGP 25E mounting diagrams

Figure 1 shows the MEGP 25E dimensions and the adapter plate provided. Each finger must be attached to the outer side of a gripper jaw using an M4X0.7 screw and two  $\varnothing 1.5$  mm locating pins.

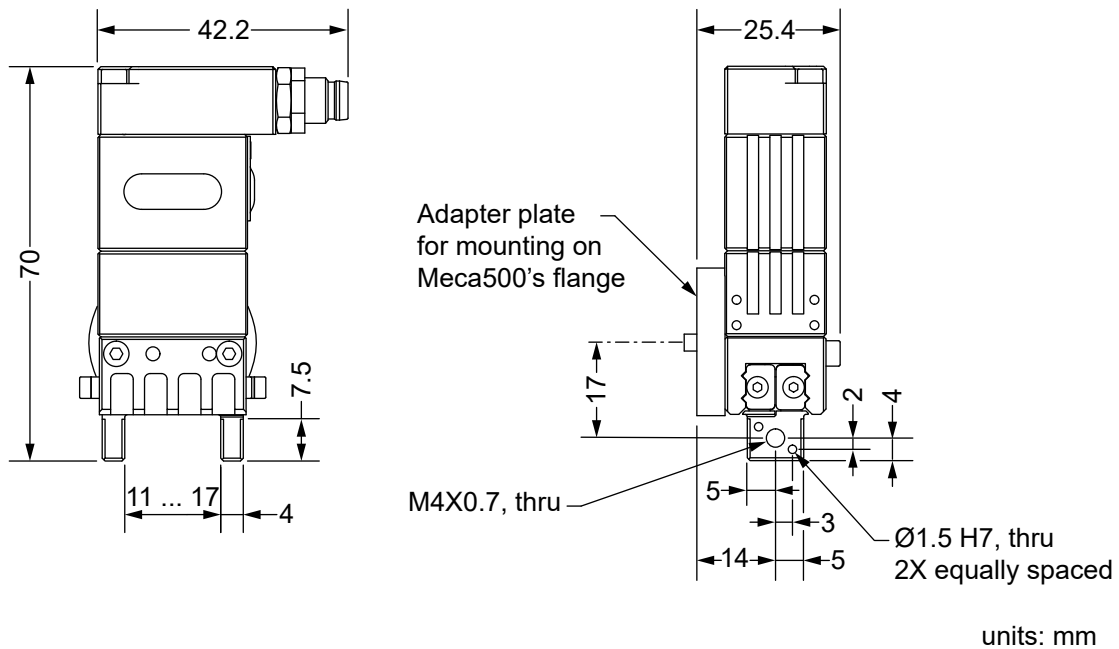

Figure 1: MEGP 25E gripper dimensions

The maximum dimensions for the fingers and the maximum loads allowed on the gripper jaws are shown in Figure 2.

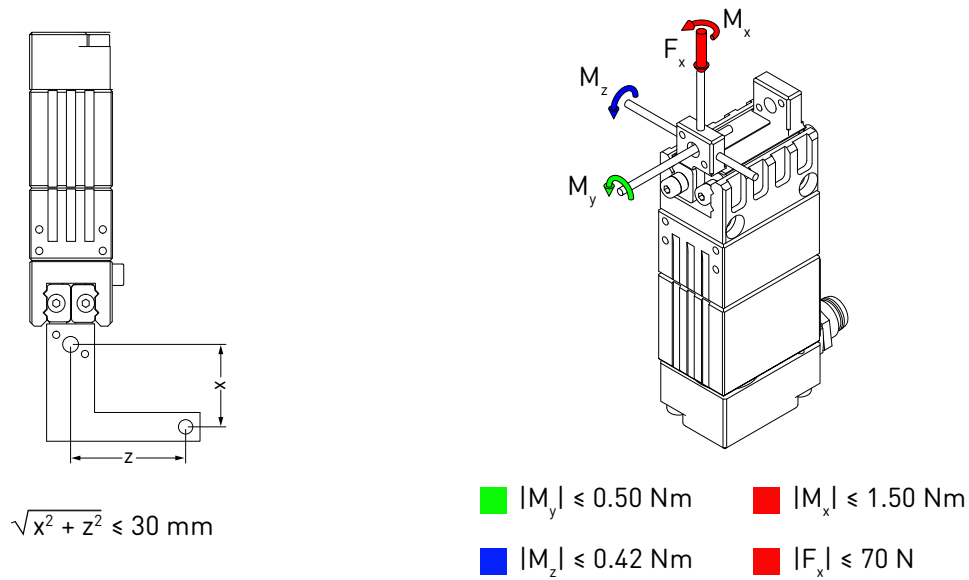

Figure 2: Maximum finger dimensions and finger loads for the MEGP 25E gripper

### 3.2. MEGP 25LS mounting diagrams

Figure 3 shows the MEGP 25LS dimensions and the adapter plate provided. Each finger must be attached to the outer side of a gripper jaw using an M4X0.7 screw and two  $\varnothing 1.5$  locating pins.

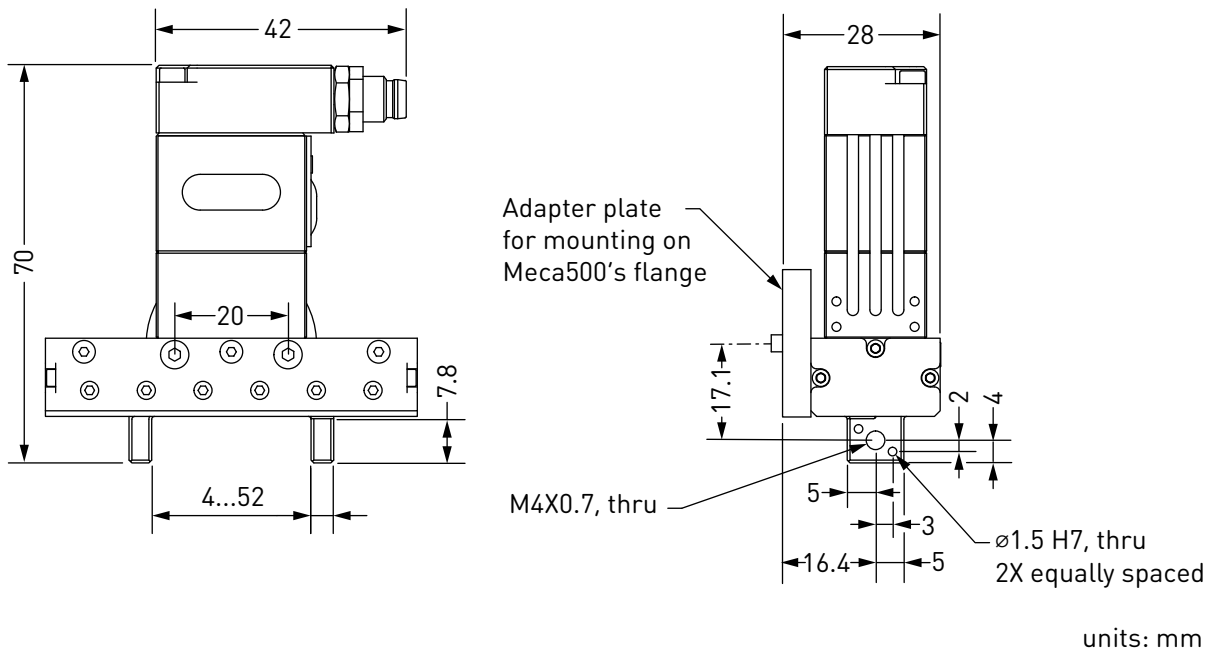
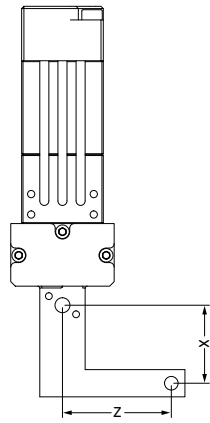
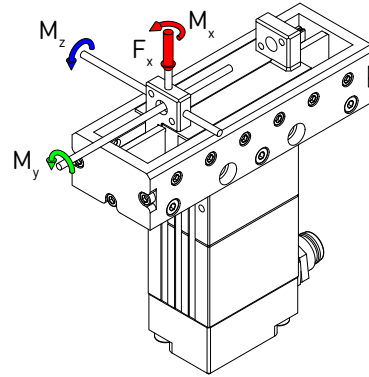

Figure 3: MEGP 25LS gripper dimensions

The maximum dimensions for the fingers and the maximum loads allowed on the gripper jaws are shown in Figure 4.



$$\sqrt{x^2 + z^2} \leq 32 \text{ mm}$$



- $|M_y| \leq 0.50 \text{ Nm}$
- $|M_x| \leq 1.30 \text{ Nm}$
- $|M_z| \leq 0.42 \text{ Nm}$
- $|F_x| \leq 70 \text{ N}$

Figure 4: Maximum finger dimensions and finger loads for the MEGP 25LS gripper

## 4. INSTALLING THE GRIPPER

The communication cables that come with the MEGP 25\* grippers are designed for only two types of installation: using the standard adapter plate or the optional 90° adapter plate. If mounting the gripper on the Meca500 flange differently, you must design and machine your own adapter plate.

### 4.1. Installation steps

Before installing the gripper, the robot must be setup properly:

1. Turn the robot on.
2. Open the MecaPortal web interface and activate and home the robot.
3. Bring all joints to zero degrees.
4. Once all joints are zeroed, switch the robot off before proceeding to install the gripper.



The robot must be powered off before proceeding to install the gripper.

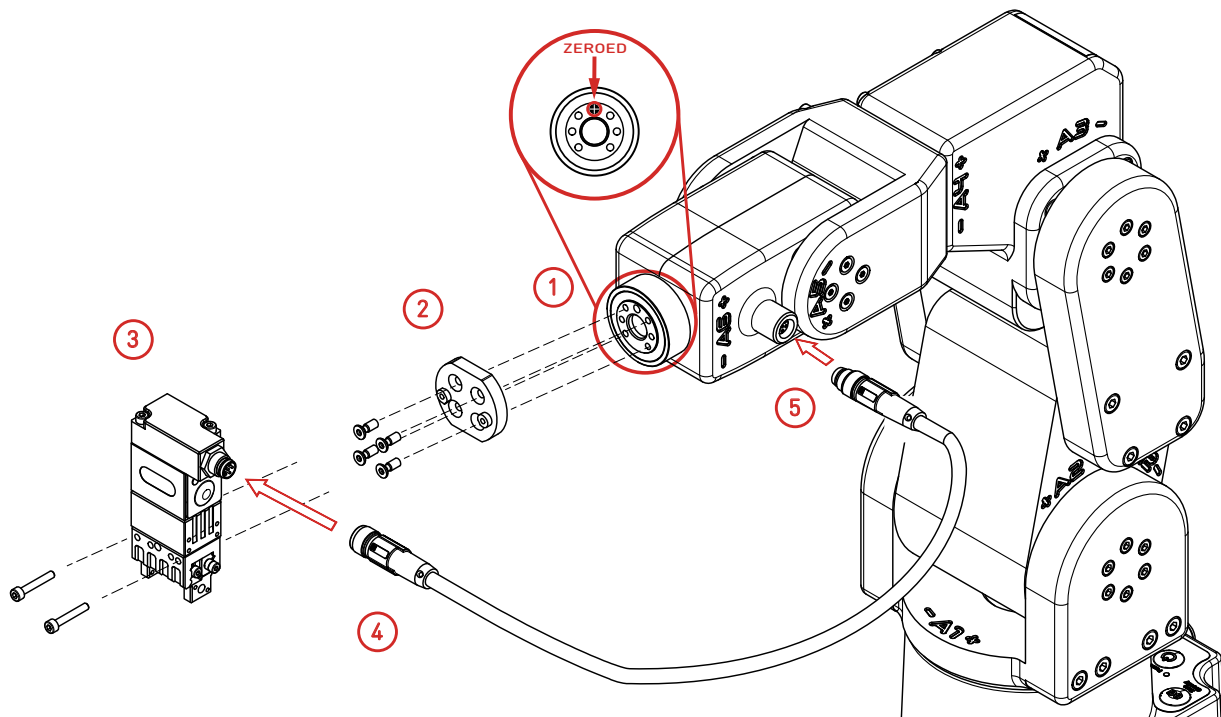

Figure 5: Installing the MEGP 25E gripper (fingers are not shown)

Install the gripper following the installation steps below, as shown in [Figure 5](#).

1. Make sure the flange of the robot is in zero position (screw in the flange is at 12 o'clock).
2. Attach the adapter plate using the four M3X0.5X8 Torx flat head screws provided. Make sure to install the plate in the proper orientation, as shown in [Figure 6](#).

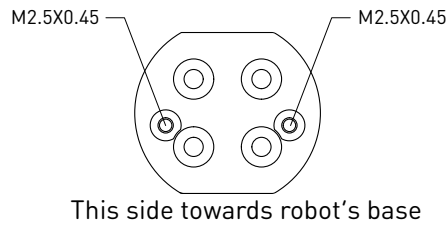

Figure 6: Proper adapter plate orientation (when all joints are at zero degrees)



Use only the screws provided; longer screws will damage joint 6.

3. Attach the gripper to the adapter plate using the two M2.5X0.45 socket head screws provided.
4. Attach the appropriate end of the cable to the gripper.
5. Remove the screw cap from the I/O tool port on the robot (keep for future use). Attach the other end of the cable to the port.

Once the gripper is installed, you can start using the robot. When the Meca500 is activated, it will automatically detect the gripper, and the green LED on the gripper will flash slowly.

The gripper is automatically homed when the robot is homed; it will fully open then close its fingers. This homing procedure is necessary to detect the range of motion of the fingers (in case their design reduces the nominal 6-mm range, for the MEGP 25E, or 48-mm range, for the MEGP 25LS). Once the gripper is homed, the green LED on the gripper will light up continuously.

[Figure 7](#) shows the MEGP 25 gripper installed and homed, in the case of both types of cables.

Now that you have installed and homed your gripper, you must carefully test and then redefine the range of joint 6 with the command `SetJointLimits` in order to make sure that the gripper cable does not cause interferences. In the case of the standard adapter plate described in this section and the optional 90° adapter plate, the recommended maximal range for joint 6 is  $[-180^\circ, 180^\circ]$ .



Once you have installed your MEGP 25\* gripper you must redefine the range of joint 6 using the command `SetJointLimits`, or else you risk to damage the gripper and its cable.

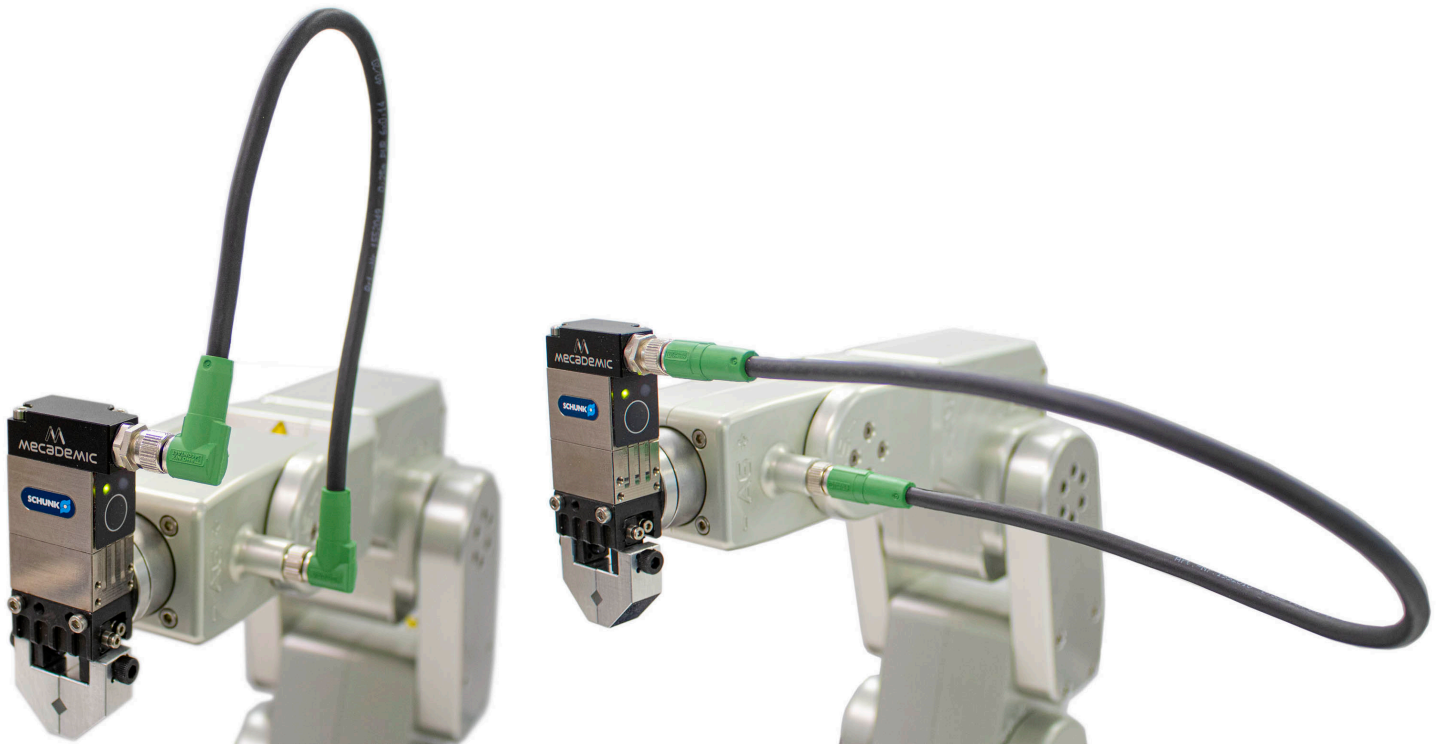

Figure 7: MEGP 25E gripper installed and homed with the two different cables

## 4.2. Gripper LEDs

There are two LEDs on the gripper, just below the I/O tool port: one green and one red. Their behavior indicates the gripper status as described in [Table 2](#).

LED	LED DESCRIPTION		
	Steady ON	Slow Blink	Fast Blink
RED	Holding part	Error	n/a
GREEN	Homed	Activated but not homed	Connected but not activated

Table 2: LED description



The button on the gripper, immediately below the two LEDs, is reserved for future use by Mecademic technicians.

## 5. OPERATING THE GRIPPERS

The MEGP 25\* grippers operate using the same commands as the Meca500. They can be opened or closed using the `GripperOpen` and `GripperClose` commands. Gripping force can be configured using the `SetGripperForce(f)` command, where *f* ranges from 5% to 100% (i.e., from 0 to approximately 40 N). By default, the grip force limit is 40%. Gripping velocity can be set using the `SetGripperVel(v)` command, where *v* is the finger velocity limit, ranging from 5% to 100% (approximately 100 mm/s). By default, the finger velocity limit is 40%.

The gripper also has position control commands such as `MoveGripper` and `SetGripperRange` that allow users to move the gripper or set a range limit. Consult the Mecademic Robots Programming Manual for more details on these commands.

### 5.1. Firmware update

If you upgrade the firmware of your robot (using the procedure described in the Meca500 User Manual) while an MEGP 25\* gripper is installed, the firmware of the gripper will be automatically updated. Otherwise, you can update the firmware of your gripper separately by following the same procedure, but selecting the file `m500_exttools_*.update`, instead of the file `Meca500_E_LD_*.update`.

### 5.2. Safety

The MEGP 25\* grippers are designed with safety in mind, however, additional parts connected to (e.g., fingers) or held by the gripper may lead to risks of injuries. Pay attention to gripping force to avoid ejecting workpieces or third-party hardware.



If the gripper is holding a part for a long time, its main body will become very hot. This is normal.

---

### 5.3. Activation, homing and E-Stop

If an activated and homed robot with an MEGP 25\* gripper becomes deactivated, the gripper fingers are no longer controlled and become freely movable. However, the fingers positioning is still being precisely measured, and you do not need to home the robot again (only re-activate it).

If an E-Stop is activated on a Meca500 R3, the whole system is powered off, while on a Meca500 R4, power is removed from the robot motors AND the MEGP 25\* gripper connected to the robot. Therefore, once the E-Stop is removed and reset, you must not only reactivate the robot, but also home it.



After an E-Stop or after deactivating the robot, the MEGP 25\* gripper no longer maintains a gripping force and if it is holding a part, the part might fall.

---

## 5.4. Maintenance

As part of regular maintenance, it is important to ensure that the MEGP 25LS gripper travels the full stroke every 1,000 cycles or at least once daily, whichever occurs first.



## Contact Us

Mecademic  
1300 St-Patrick Street  
Montreal (Quebec) H3K 1A4  
Canada

1-514-360-2205  
1-833-557-6268 (toll-free in North America)

<https://support.mecademic.com>

**MECADEMIC**  
INDUSTRIAL ROBOTICS

© Copyright 2015–2023 Mecademic